

A: Component Parts

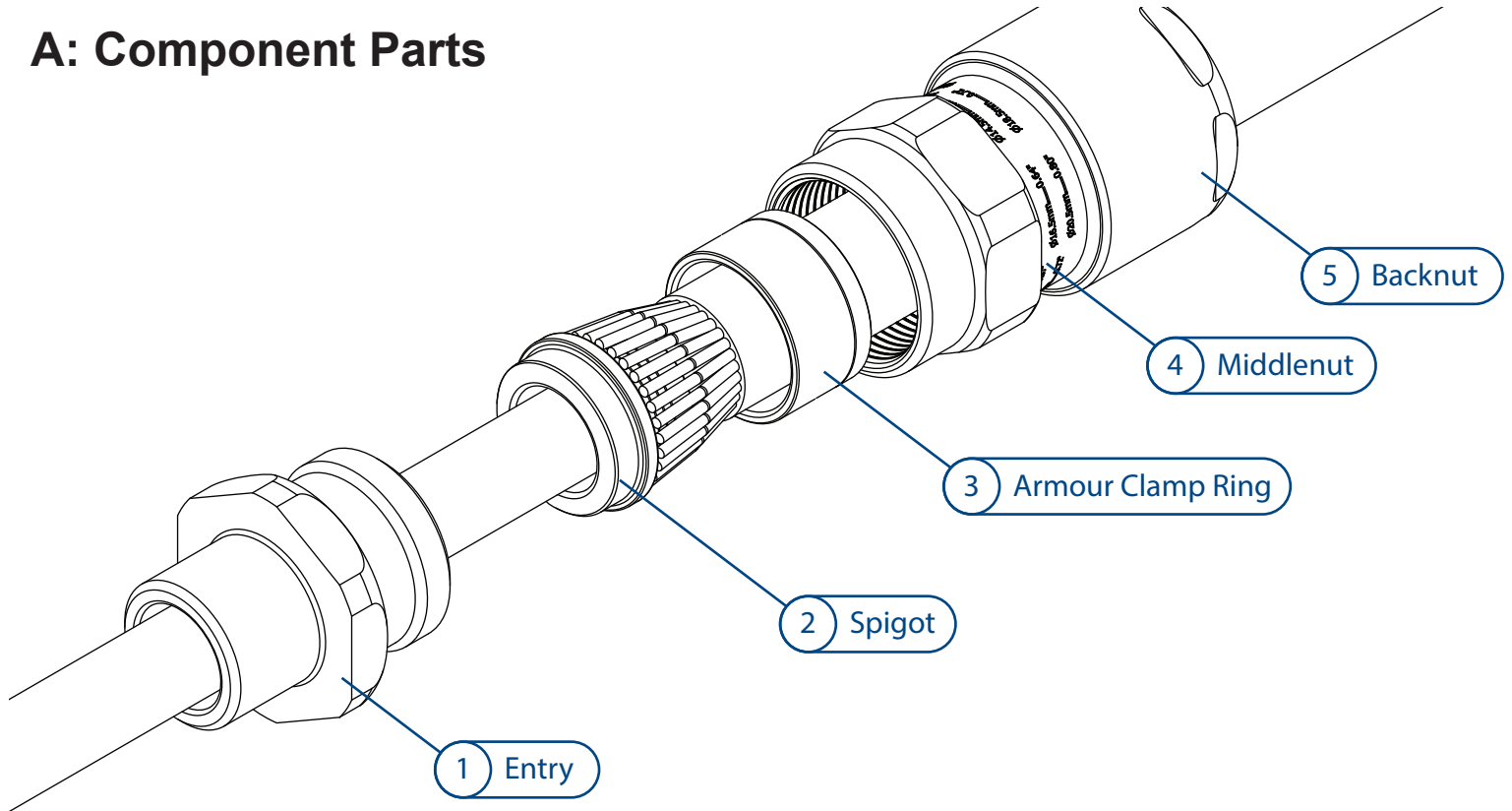

B: Cable Preparation

Slide shroud (if included), backnut ⑤, middenut ④ and armour clamp ring ③ onto cable. Confirm orientation of armour clamp ring is correct (see table below). Cut cable length, strip outer sheath and cut armour to lengths as shown in table below.

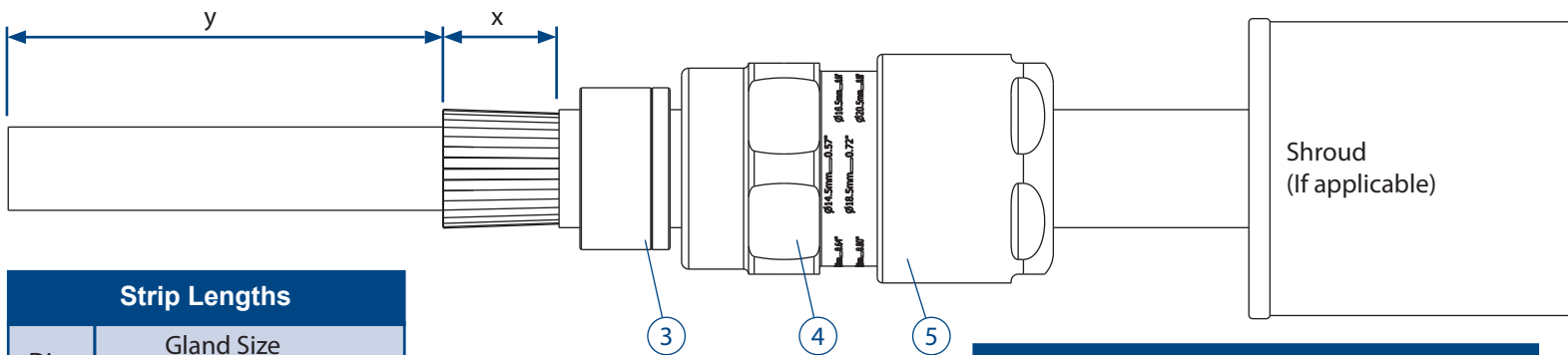

Strip Lengths			
Dim	Gland Size		
	Os-C	C2-F	G-J
x	20mm	25mm	32mm
y	To suit equipment		

Armour Clamp Ring Orientation		
Gland Size	Orientation	
	Equipment Side	Equipment Side
Os-A	0.8 - 1.25mm	0 - 0.8mm
B	1.25 - 1.6mm	0 - 0.7mm
C-C2	1.6 - 2.0mm	0 - 0.7mm
D-F	1.8 - 2.5mm	0 - 1.0mm
G-H	2.0 - 3.5mm	0 - 1.0mm
J	2.5 - 4.0mm	0 - 1.0mm

Tape Armour

After tape is spread, ensure ends are trimmed at 90° as shown

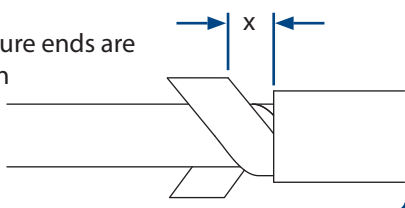

C: Installing Cable Gland

STEP 1: Fit Armour To Spigot

Slide spigot ② over cable.

Push armour/braid up to spigot shoulder.

Slide clamping ring ③ up to the armour/braid by hand.

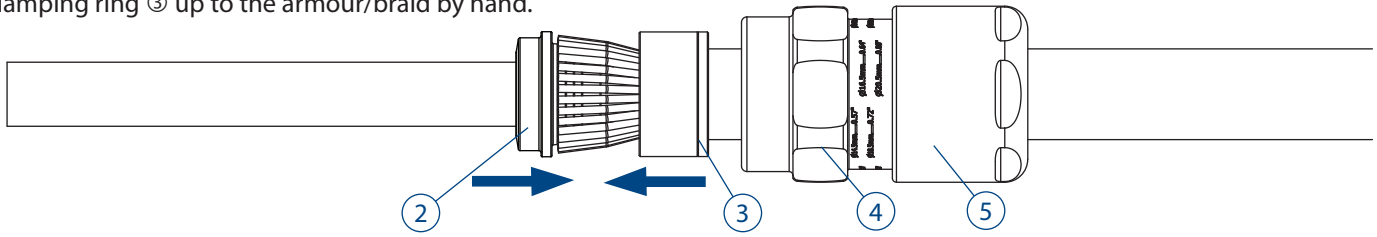

STEP 2: Prepare to Clamp Armour/Braid

Slide Entry ① over cable.

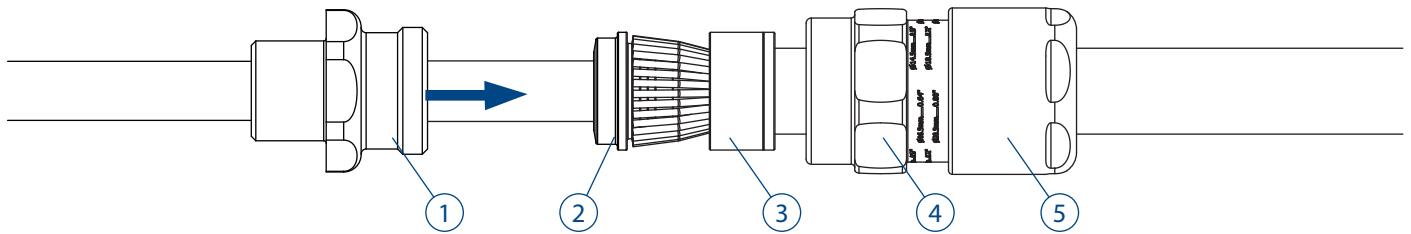

STEP 3: Clamp Armour/Braid

Slide middle nut ④ up to entry and hand tighten.

If not already screwed into equipment, grip the entry ① with a spanner/wrench.

Use a second spanner/wrench to tighten half to three quarters of a turn.

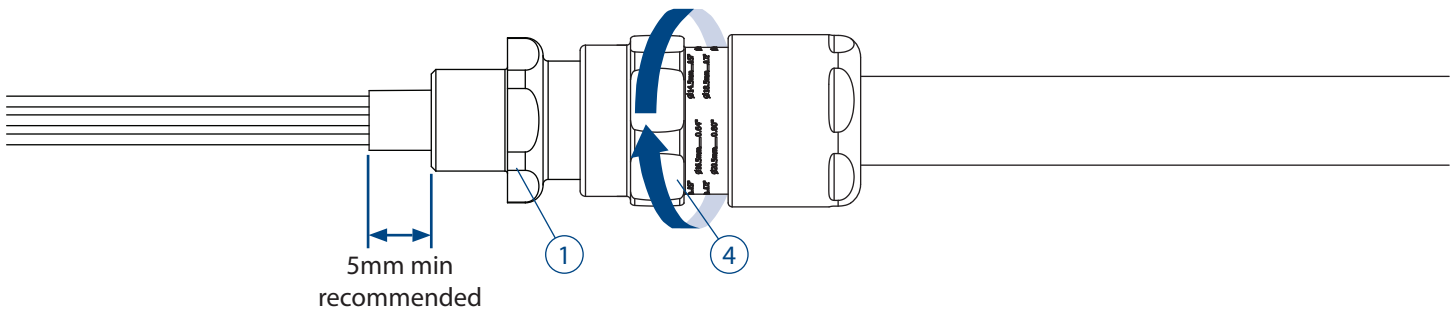

NOTE: Support the cable to prevent it twisting. To aid wiring inside the enclosure, it may be beneficial to strip the inner sheath as shown above.

STEP 4: Inspect Armour/Braid

Unscrew the middle nut ④. The armour clamp ring ③ should now be locked in place.

Visually inspect that the armour/braid has been successfully clamped between the spigot ② and the armour clamp ring ③.

If clamping is not satisfactory, repeat step 3.

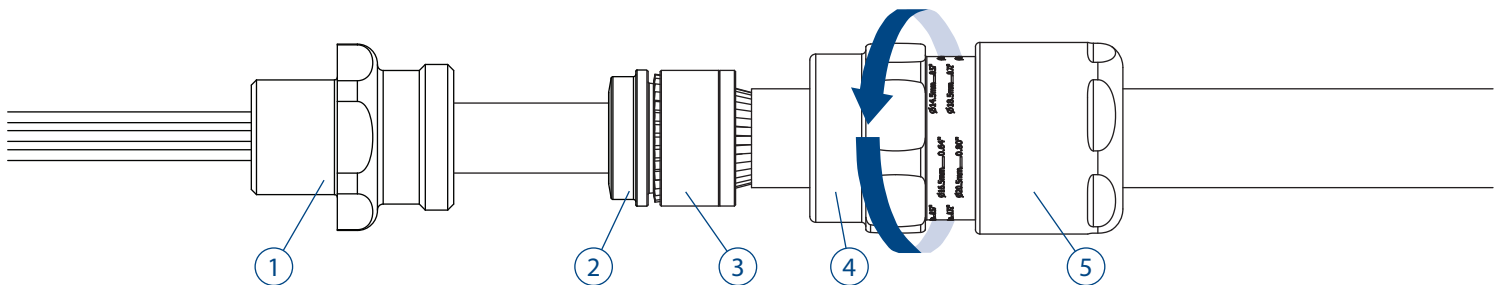

STEP 5: Reassemble

Replace entry ① to enclosure. If required, use the appropriate IP washer.
With inner seal properly seated into the entry, tighten up the middle nut by hand.
Using a wrench/spanner tighten a further 1/6 turn.

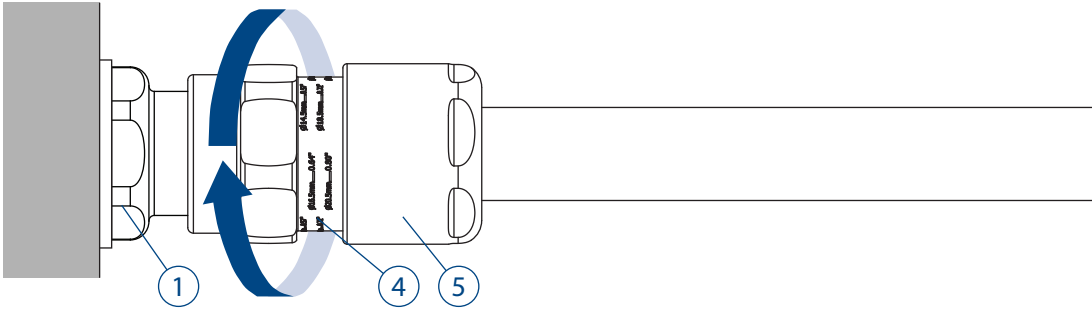

STEP 6: Install Backnut

Tighten the backnut ⑤ until a seal is formed around the cable.
Use a wrench/spanner to grip the middle nut ④.
While preventing the middle nut ④ turning, use a second wrench to apply one further full turn to the backnut ⑤.

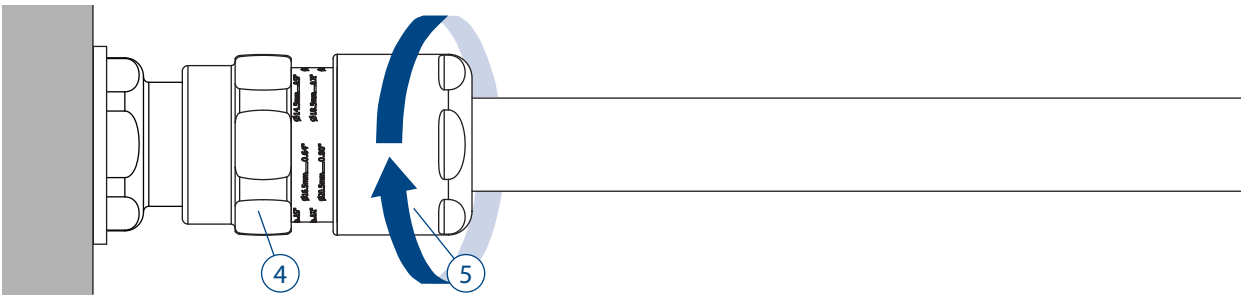

STEP 7: Inspect Backnut

Use the middle nut ④ guide as an indication that the backnut ⑤ is in the correct position to suit cable diameter.
A diameter scale below is provided to assist this process.
Slide shroud over cable gland if applicable.

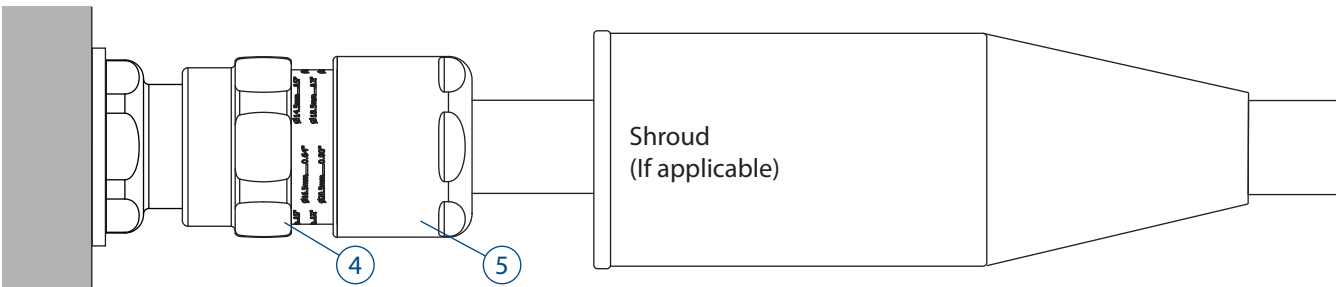

TECHNICAL DATA

Cable Gland Type: 151 RAC
Equipment Type: Industrial General Purpose
Ingress Protection: IP66
Operating Temp: -60°C to +100°C

ACCESSORIES

Hawke offer the following accessories to enable correct sealing and ground of cable gland.

Shroud: For additional corrosion protection
Locknut: To secure gland into position
Sealing Washer: For additional ingress protection
Earth Tag: For external bonding point
Serrated Washer: To prevent vibration loosening locknuts

INSTALLATION NOTES

1. All cable glands must be installed by a suitably trained and competent individual.
2. Entry threads are in accordance with Metric BS3643 or NPT B1.20.1
3. Installer must check material compatibility with enclosure and environment.
4. To maintain IP66, Hawke sealing washer or other approved sealing method must be used.
5. Sealing face surface must be smooth and free from damage
6. Wall thicknesses depended on thread length or retention type (locknut etc).
7. All entries must be installed perpendicular to the mounting surface.
8. When used with steel basket weave armour or braided cable, the cable must be clamped and cleated to prevent pulling on the armour or braid of the cable.

CABLE GLAND SELECTION TABLE										
Size Ref.	Entry Thread Size		Cable Acceptance Details					Maximum Length	Hexagon Dimensions	
			Inner Sheath	Outer Sheath		Steel Wire Armour/ Tape/Braid				
	Standard Seal	Orientation 1	Orientation 2							
	Metric			NPT	Max.	Min.	Max.		Across Flats	Across Corners
Os	M20	½"	8.0	5.5	12.0	0.8/1.25	0/0.8	73.0	24.0	26.5
O	M20	½"	11.9	9.5	16.0	0.8/1.25	0/0.8	73.0	24.0	26.5
A	M20	½" - ¾"	14.3	12.5	20.5	0.8/1.25	0/0.8	74.0	30.0	32.5
B	M25	¾" - 1"	20.2	16.9	26.0	1.25/1.6	0/0.7	82.0	36.0	39.5
C	M32	1" - 1¼"	26.5	22.0	33.0	1.6/2.0	0/0.7	88.0	46.0	50.5
C2	M40	1¼" - 1½"	32.5	28.0	41.0	1.6/2.0	0/0.7	91.0	55.0	60.6
D	M50	1½" - 2"	42.3/44.4	36.0	52.6	1.8/2.5	0/1.0	113.0	65.0	70.8
E	M63	2" - 2½"	54.3/56.3	46.0	65.3	1.8/2.5	0/1.0	117.0	80.0	88.0
F	M75	2½" - 3"	65.3/68.2	57.0	78.0	1.8/2.5	0/1.0	115.0	95.0	104.0
G	M80	3½"	73.0	75.0	89.5	2.0/3.5	0/1.0	121.0	106.4	115.0
H	M90	3½"	77.6	75.0	89.5	2.0/3.5	0/1.0	121.0	115.0	130.0
J	M100	4"	91.6	88.0	104.5	2.5/4.0	0/1.0	121.0	127.0	142.0

* Sizes Os and O are available with an M16 thread size. If M16 entry is used on O size cable glands the maximum cable inner sheath diameter is limited to 10.9mm.

CABLE GLAND CLASSIFICATION															
Material			Mechanical Properties				Electrical Properties				External Influences			Sealing System	
Metal	Non-Metallic	Composite	Without Cable Anchorage	With Cable Anchorage	Impact Category	Cable Retention (Armoured Cable)	Equipotential Bonding	Connection to Metallic Layers	Protective Connection to Earth	Insulation Characteristics	Ingress Protection	Temperature Range	Resistance to Salt and Sulphur Dioxide Laden Atmospheres	Single Orifice Seal	Multi-Orifice Seal
				Type	Category	Class			Category		IP66	-60° to 100°			
Y	X	X	X	A	8	B	Y	Y	C	X	Y	Y	Y	Y	X

EU Declaration of Conformity in accordance with European Directive 2014/34/EU

Standards used: EN 62444 : 2013

On behalf of the aforementioned company, I declare that, on the date the equipment accompanied by this declaration is placed on the market, the equipment conforms with all technical and regulatory requirements of the above listed directives.

.....
A. Reid
Technical Manager